

**ISUZU BERPENGALAMAN DENGAN
MESIN COMMON RAIL SEJAK 2011**

ISUZU
ELF
NLR



**IRIT MAKSIMAL,
TENAGA OPTIMAL**

**euro4
ready**

*Gambar pada brosur ini hanya ilustrasi, mungkin ada perbedaan dengan aktual kendaraan
**Mesin common rail pada Isuzu Giga sejak tahun 2011

REAL PARTNER. REAL JOURNEY.

SPESIFIKASI TEKNIS

SPESIFIKASI		NLR	NLR L
DIMENSI / DIMENSION			
Panjang / Overall Length [OAL]	mm	4,700	6,000
Lebar / Overall Width [OW]	mm	1,835	1,835
Tinggi / Overall Height [OH]	mm	2,205	2,205
Jarak Sumbu / Wheelbase [WB]	mm	2,490	3,360
Julur Depan / Front Overhang [FOH]	mm	1,110	1,110
Julur Belakang / Rear Overhang [ROH]	mm	1,100	1,530
Jarak Terendah ke Tanah / Minimum Clearance [HH]	mm	220	220
Jejak Depan / Front Tread [AW]	mm	1,475	1,475
Jejak Belakang / Rear Tread [CW]	mm	1,395	1,395
Cabin to End [CE]	mm	3,127	4,427
MESIN / ENGINE			
Model		4JJ1-TCC	
Tipe / Type		Direct Injection, Commonrail, DOHC, 4 Cylinder with VGS Turbo Intercooler	
Sistem Kontrol Emisi		EURO4 with EGR & DOC	
Diameter x Langkah / Bore x Stroke	mm	95.4 X 104.9	
Isi Silinder / Piston Displacement	cc	2,999	
Tenaga Maksimum / Maximum Power	PS/rpm	120 / 2,600	
Torsi Maksimum / Maximum Torque	Kgm/rpm	36 / 1,500 - 2,600	
TRANSMISI / TRANSMISSION			
Model		MY6S	MY6S
Perbandingan Gigi / Gear Ratio			
	1st	5.979	5.979
	2nd	3.434	3.434
	3rd	1.862	1.862
	4th	1.297	1.297
	5th	1.000	1.000
	6th	0.759	0.759
	Rev	5.701	5.701
Perbandingan Gigi Terakhir / Final Gear Ratio		4.300	4.777

SPESIFIKASI		NLR	NLR L
BERAT / WEIGHT			
Berat Kosong Kendaraan / Curb Weight	kg	1,864	1,986
Berat Total Kendaraan / Gross Vehicle Weight [GVW]	kg	5,100	5,100
Kapasitas Gardan Depan / Capacity Front Axle	kg	2,330	2,200
Kapasitas Gardan Belakang / Capacity Rear Axle	kg	2,770	2,900
REM / BRAKE			
Tipe/Type		Hydraulic	
Rem Kaki / Service Brake		Hydraulic saluran ganda dengan vacum booster	
Rem Tangan / Hand Brake		Expanding pada transmisi belakang	
Sistem Pengereman Gas Buang / Exhaust Brake		Exhaust brake, tuas berada di stir	
RODA / TYRE			
Ukuran Ban		7.50-15-12PR	7.50-15-14PR
Ukuran Velg		15 X 5.50	15 X 5.50
SUSPENSII / SUSPENSION			
Depan / Front		Semi elliptical laminated leaf spring dengan shock absorber berdaya ganda	
Belakang / Rear			
LAIN-LAIN / OTHERS			
Kapasitas Tangki / Fuel Tank Capacity	ltr	75	100
Radius Putar Minimum / Minimum Turning Radius	m	5.7	7.3
Daya Tanjak Maksimum / Maximum Gradeability	%	44	52
Kecepatan Maksimum / Maximum Speed	km/h	120	114
Aki / Accu	V-Ah	2 X 12 V - 60 Ah	
Alternator	V-A	24 - 50	
Kamera Mundur / Reverse Parking Camera		Ada	
Audio Head Unit		Ada	
USB Charging System		Ada	
APAR (Alat Pemadam Api Ringan)		Ada	
Fan Blower		Ada	
Garansi / Warranty		3 Tahun / 100,000 km	

* Untuk meningkatkan mutu dan penyesuaian dengan perkembangan teknologi, spesifikasi dapat berubah sewaktu-waktu tanpa pemberitahuan. ** Ilustrasi merupakan contoh sebagian aplikasi di lapangan.

DIMENSI

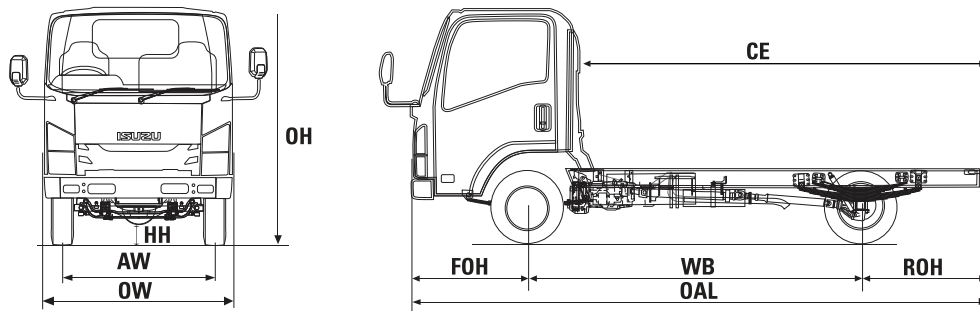

APLIKASI

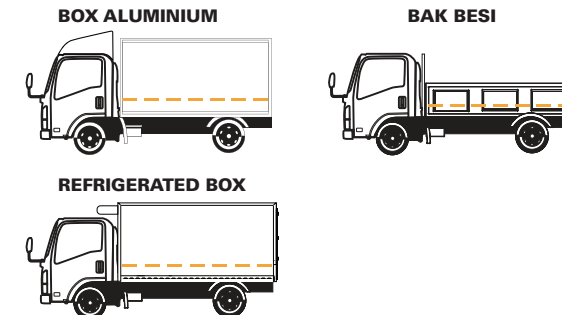

SCAN INI
UNTUK
INFORMASI
LEBIH LANJUT